



HYDRAULIC VALVES

(DIRECTIONAL CONTROL)

SELECTOR VALVES SD5 SERIES

Specification Sheet

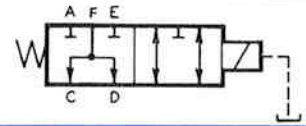

The CROSS SD5 2-wheel/4-wheel selector valve is a special version of the SD series valve with a special spool and body. It has been specifically designed for use with hydrostatic transmissions and permits selection of either 2-wheel (Transport mode) or 4-wheel (Work mode) drive positions.

GENERAL SPECIFICATIONS

- Maximum working pressure..... 5000 psi (345 bar)
- Maximum shock and surge pressure..... 6000 psi (414 bar)
- Maximum flow capacity..... 50 gpm (189.3 l/m)
- Shipping weight..... 10 lbs. (4.5 Kg)
- Mounting..... 2-bolt, any position

MATERIAL SPECIFICATIONS

- Body High tensile strength cast iron
- Spool Ground, plated and polished steel
- Seals Buna N

STANDARD FEATURES

- 1 1/16 - 12 (3/4", SAE #12) ports
- 2-wheel/4-wheel selector spool
- 12 VDC solenoid actuator
- Spring return
- 7/16-20 charge pressure port

OPTIONAL FEATURES AVAILABLE

- 3/4-16 (1/2", SAE #8) ports
- 3/4" NPTF ports
- Actuator at either side
- 1 5/16-12 (1", SAE #16) ports
- Handle actuator
- Pilot actuator
- Knob
- Clevis
- Charge pressure port sizes to 1 5/16-12

APPLICATION

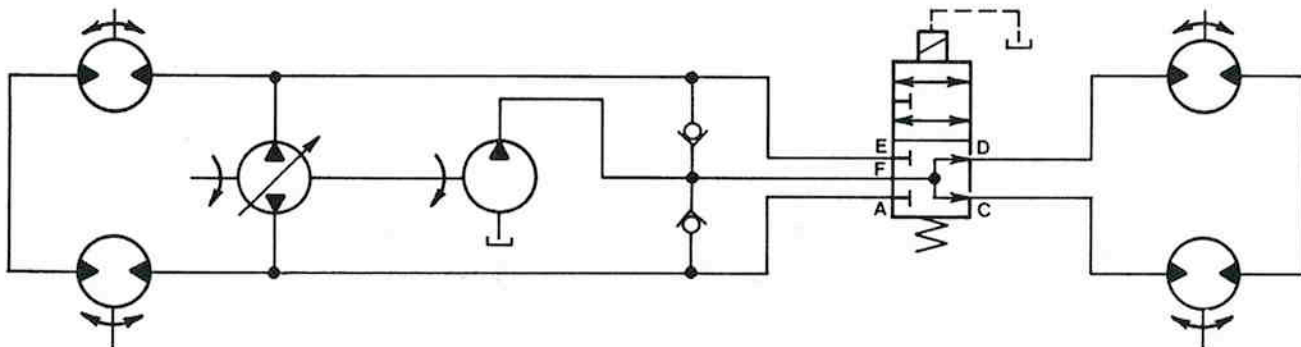

Note that when in 2-wheel drive, supercharge oil is supplied to the non-driving wheels, preventing cavitation. When operating in 2-wheel drive for long periods of time, it may be necessary to occasionally shift into 4-wheel drive in order to cool the non-driving wheel motors.



DIMENSIONAL DATA in inches and (millimeters)

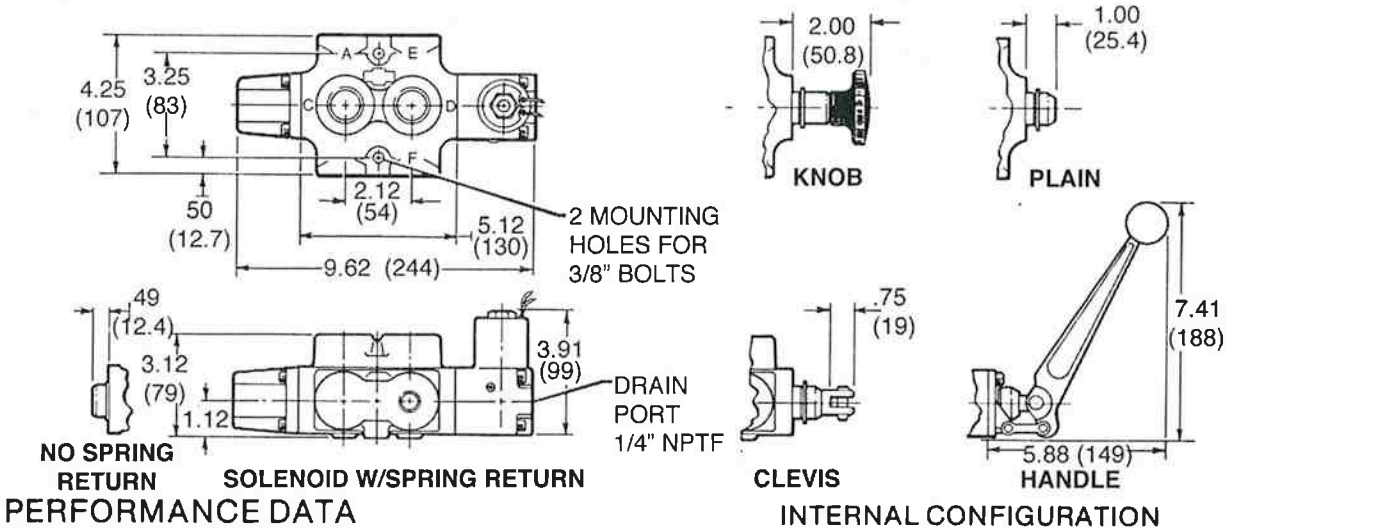

PERFORMANCE DATA

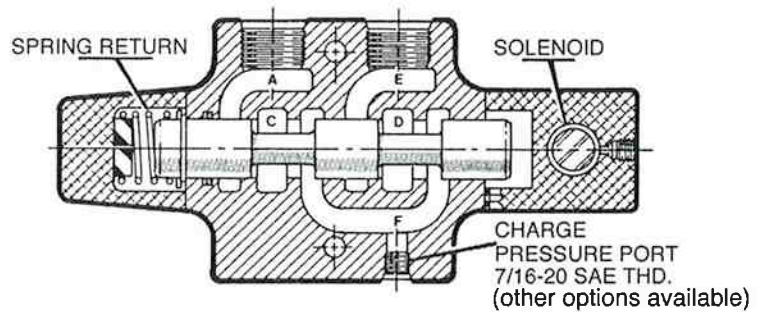
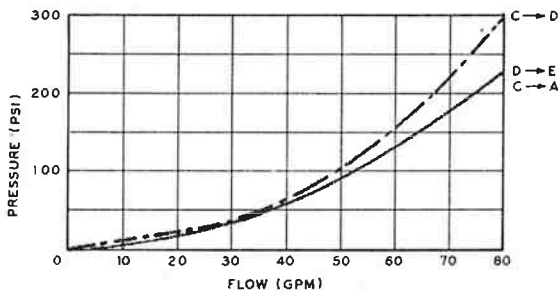

ORDERING DATA

SERIES	MODEL	ACTUATOR LOCATION	ACTUATOR OPTIONS	END CAP OPTIONS	SPOOL TYPE	PORT SIZE (PORTS A, E, C, D)
SD	5 50 gpm	A Port C side B Port D side	A - Handle C - Clevis K - Knob L - Plain S - 12v DC Solenoid T - 24v DC Solenoid U - Hydraulic Pilot G - Other, Specify	L - Plain B - Spring Return D - 2 pos. Detent U - Hydraulic Pilot G - Other Specify	A 2-wheel/4-wheel selector	2 3/4-16 (SAE 8) 4 3/4" NPTF 5 1 1/16-12 (SAE 12) 7 1 5/16-12 (SAE 16)
SD	5	B	S	B	A	5

Example: SD5BSBA5 is a 2-wheel/4-wheel selector valve with 12v DC solenoid actuator at the "D" port side with spring return and 1 1/16 - 12 (SAE 12) ports.



CROSS MANUFACTURING, INC.
100 James H. Cross Blvd.
Lewis, Kansas 67552
Phone 620/324-5525; FAX 620/324-5737; e-mail: info@crossmfg.com