

The **CROSS** sequence or **SQV** valve is designed to alternately operate a pair of **agricultural guide marker cylinders** on a row marker system.

### OPERATION:

**System diagram and valve layout** represent the main cylinder "C" in retracted position (*implement down*), with marker cylinder "A" extended (*marker up*). Marker cylinder "B" is retracted (*marker down*).

**At the end of a row**, cylinder "C" is extended to lift the implement pressurizing ports "A" and "B" through the sequence valve spool. Marker cylinder "B" would then extend (*marker up*). No flow would pass through "A" port since cylinder "A" is already extended. This condition causes a pressure drop between the "A" & "B" port ends of the sequence valve which shifts the spool to the "B" port end.

**Starting a new row**, main cylinder "C" is retracted (*implement down*) pressurizing marker cylinders "A" and "B" to retract. However, port "B" flow passages are blocked by the spool and integral check in "B" port. Consequently, only marker cylinder "A" is allowed to retract (*marker down*). **Upon completion of this row**, main cylinder "C" is again extended, and the marker cylinder "A" is raised. The pressure differential on the spool shifts the spool to the port "A" end preparing marker cylinder "B" to be lowered. Once the implement and "B" port marker are lowered, **the guide marker system will have completed its full cycle and be back in its original position.**

### **Features:**

- 2 position, 3 port (3/4-16 SAE)
- M18 x 1.5 threads also available
- Rated to 2500 psi, 2 gpm
- Rugged construction
- 100% testing

### STANDARD INSTALLATION SHOWN WITH IMPLEMENT CYLINDER

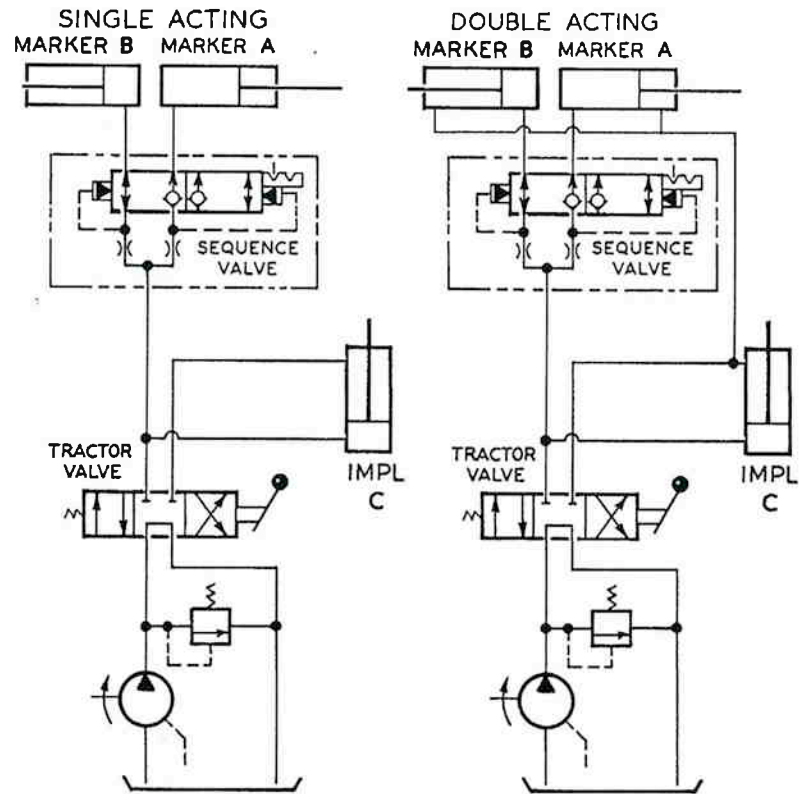

### DIRECT HOOK-UP

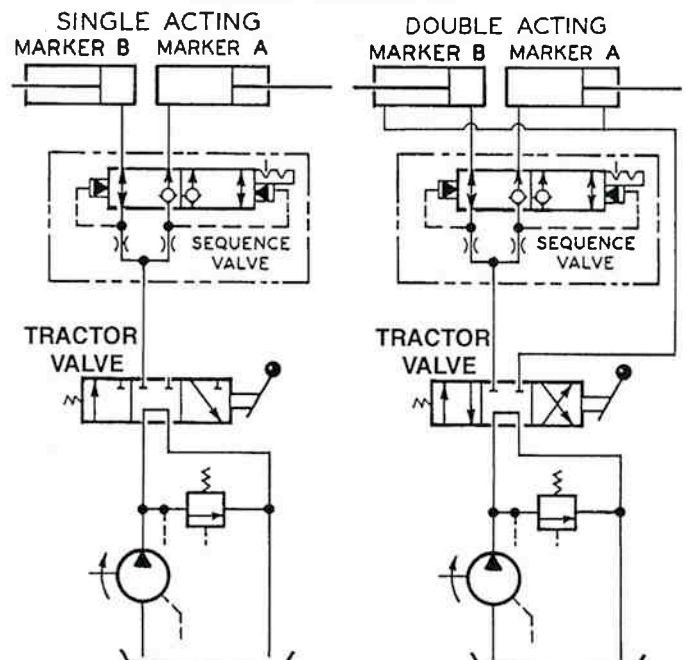

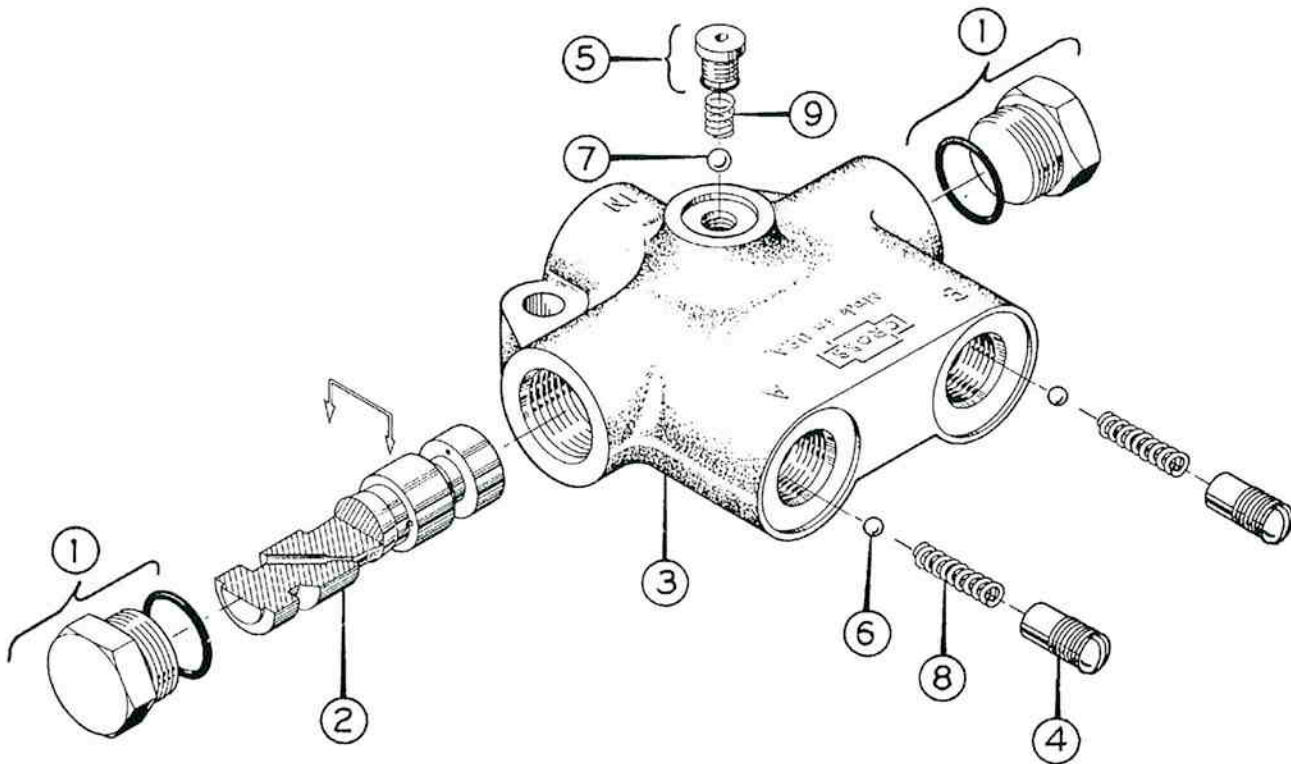

PARTS LIST

○	PART NO.	DESCRIPTION	QTY
1	1V1880	O-RING BOSS PLUG ASSEMBLY . . . . .	2
2	1V1882	* SPOOL . . . . .	1
3	1V2003	* BODY MACHINING . . . . .	1
4	1V2001	CHECK VALVE RETAINER . . . . .	2
5	3V4153-022	O-RING BOSS PLUG ASSEMBLY . . . . .	1
6	2A0017-6	BALL ( 3/16" ) . . . . .	2
7	2A0017-8	BALL ( 1/4" ) . . . . .	1
8	2A9018-3	CHECK VALVE SPRING . . . . .	2
9	2A9024-1	SPRING . . . . .	1
	2A0353-12	SHIPPING PLUG . . . . .	3

\* THE SELECT-FIT HONING PROCESS AT FACTORY, WHICH FITS A SPOOL TO AN INDIVIDUAL VALVE BODY, ELIMINATES THE POSSIBILITY OF ORDERING THE VALVE BODY OR SPOOL AS SEPARATE ITEMS.



CROSS MANUFACTURING, INC.  
 100 James H. Cross Blvd.  
 Lewis, Kansas 67552  
 Phone 620/324-5525; FAX 620/324-5737; e-mail: info@crossmfg.com