



HYDRAULIC VALVES

(DIRECTIONAL CONTROL)

SELECTOR VALVES
VS SERIES
Specification Sheet



The CROSS series VS hydraulic selector valves are manually operated, spool type, 3-way, 2-position valves featuring cast-in metering notches for smooth operation. They provide an economical method of diverting flow to either of two hydraulic circuits and are available with a variety of actuators.

GENERAL SPECIFICATIONS

Maximum working pressure.....	*2500 psi (172 bar)
Maximum shock and surge pressure.....	3500 psi (242 bar)
Maximum flow capacity.....	VS2: 20 gpm (76 l/m) ... VS4: 40 gpm (151 l/m)
Mounting.....	2-bolt, any position
Shipping weight	VS2: 2.7 lbs. (1.2 Kg). VS4: 6 lbs. (2.7 Kg)

* 3000 psi with SAE straight thread ports

MATERIAL SPECIFICATIONS

Body	High tensile strength cast-iron
Spool	Ground, plated and polished steel
Seals	Buna N

STANDARD FEATURES (See CROSS Full Line Catalog)

- VS 2 - 1/2" NPTF or 3/4-16 (SAE #8) ports
- VS 4 - 3/4" NPTF or 1 1/16-12 (SAE #12) ports
- Knob actuator (at port "B")
- Front inlet port position

OPTIONAL FEATURES AVAILABLE

- Actuators include spring return, detents, handles, and solenoid operators: (must be externally piloted and drained - see FM VSOS)

TYPICAL APPLICATIONS (Simplified circuits)

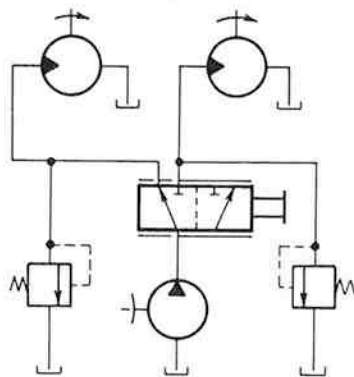

CIRCUIT SELECTOR
Allows either motor to be driven unidirectionally.

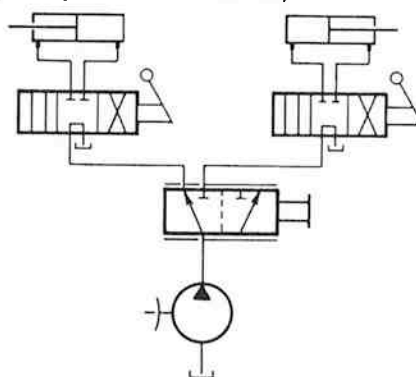

CIRCUIT SELECTOR
Allows either cylinder to be operated independently from single pump.

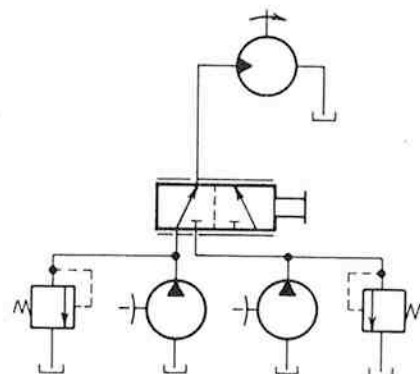

INPUT SELECTOR
Allows motor to be driven from either of two input sources.



DIMENSIONAL DATA: in inches and (millimeters)

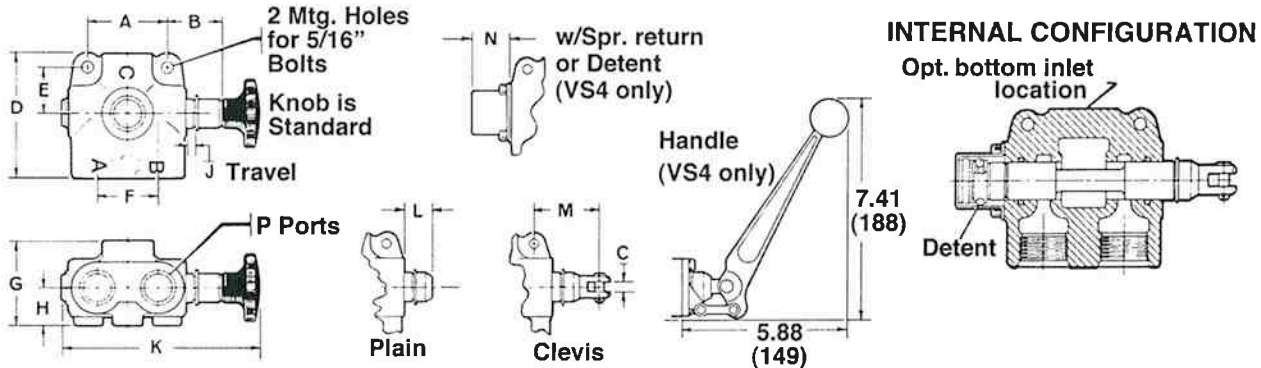

MODEL		A	B	C	D	E	F	G	H	J	K	L	M	N	P
VS2	in.	2.12	1.53	.34	3.25	1.19	1.62	2.25	1.00	.31	5.33	1.03	2.16	1.18	3/4-16
	mm	54	39	8.6	82	30	41	57	25.4	7.9	135	26	55	30	SAE #8
VS4	in.	3.00	1.56	.34	4.12	1.50	2.12	2.62	1.12	.38	6.12	1.00	2.19	1.18	1 1/16-12
	mm	76	40	8.6	105	38	54	66	28	9.6	155	25.4	56	30	SAE #12

PERFORMANCE DATA: (Typical)

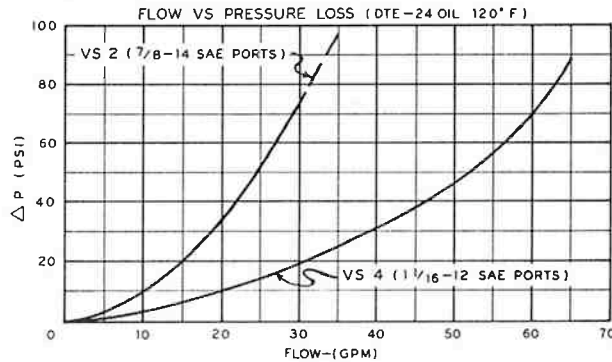

ORDERING INFORMATION

SERIES	MODEL	ACTUATOR LOCATION	ACTUATOR OPTIONS	END CAP OPTIONS	INLET PORT (C) LOCATION	PORT SIZE (ALL)	
						VS2	VS4
VS	2 20 gpm 4 40 gpm	A port "A" side B port "B" side	K Knob C Clevis L Plain	L Plain	F Front position B Bottom position A Both pos. mach.	1	6
						3/8 NPTF	3/4 NPTF
			2	7			
			VS4 only	VS4 only			
			A - Handle U - Hydraulic pilot G - Other, specify	B - Spring return D - 2 pos. detent U - Hydraulic pilot G - Other, specify			
						3 SAE#6(9/16-18)	1 NPTF
						4 SAE #8 3/4-16	8 SAE #12 1 1/16-12
						5 SAE# 10 7/8-14	9 SAE #16 1 5/16-12

Example: Model VS4BKLF8 is a standard 40 GPM valve with a knob actuator located at the "B" port side with SAE #12 (1 1/16-12) o-rings ports.



CROSS MANUFACTURING, INC.
100 James H. Cross Blvd.
Lewis, Kansas 67552
Phone 620/324-5525; FAX 620/324-5737; e-mail: info@crossmfg.com