

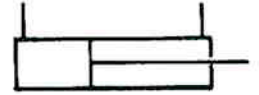

# HYDRAULIC CYLINDERS

TIE ROD CYLINDERS  
DH SERIES  
Specification Sheet



The DH cylinder is rated to a full 3000 psi working pressure and designed for tough applications. It is the cylinder of choice for today's higher pressure systems. Upgraded castings and heavy duty seals assure peak performance and a long and dependable service life.

## GENERAL SPECIFICATIONS

Rated continuous working pressure (Max. relief valve setting at full flow) . . .3000 psi (207 bar)  
Maximum proof pressure . . . . .6000 psi (414bar)

Bore diameters . . . . .	2.00	2.50	3.00	3.50	4.00	inches
	51	64	76	89	102	mm

## MATERIAL SPECIFICATIONS

Cylinder barrels . . . . . ST52.3 steel alloy  
Pistons . . . . . Aluminum alloy  
Rods . . . . .Induction hardened C1045 steel alloy  
Base castings and rod clevises . . . . . Ductile iron  
Cylinder heads . . . . .High tensile strength grey iron on 2" and 2 1/2" bores  
Ductile iron 3" bore and up  
Seals . . . . .O-ring with backup on tube; Crown seal on piston  
Double lipped polyurethane u-cup rod seal

## STANDARD FEATURES

- Cylinder barrels are skived burnished precision finished to provide long seal life
- Rods are hardened, chrome plated and polished for long wear life and for protection from external damage corrosion
- Rod wipers clean dirt and foreign matter from rod to insure long seal life
- High tensile strength tie rods with rolled threads for durability
- Double ported base allows connections to be made at 90° to pins
- SAE straight thread o-ring ports
- Hardened steel pins 3", 3 1/2" and 4" bore

## OPTIONAL FEATURES

- Bushings
- Breather plugs



DIMENSIONAL DATA in inches and (millimeters)

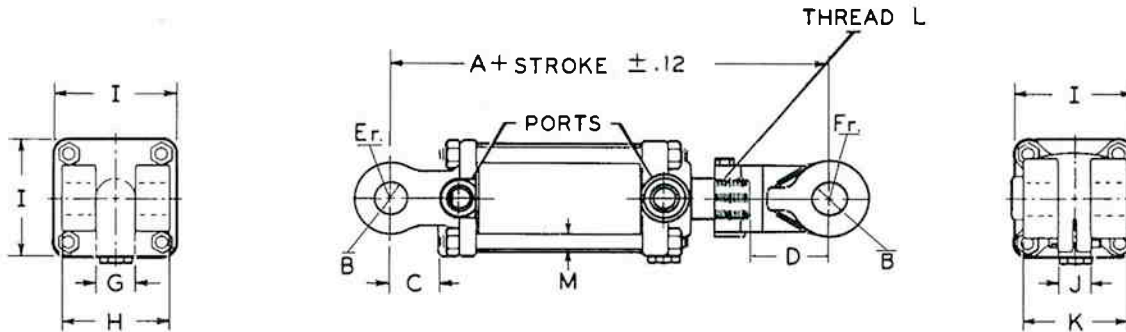

ALL DIMENSIONS ARE NOMINAL and ARE FOR STANDARD CONFIGURATIONS

BORE DIA.	A	B	C	D	Er.	Fr.	G	H	I	J	K	L	M
2.00 (51)	10.25 (260)	1.015 (25.8)	1.625 (41.3)	2.125 (53.9)	.875 (22.2)	1.000 (25.4)	1.125 (28.6)	2.500 (63.5)	2.875 (73.0)	1.125 (28.6)	2.625 (66.7)	1 <sup>1</sup> / <sub>16</sub> -12	.375 (9.5)
2.50 (64)	10.25 (260)	1.015 (25.8)	1.625 (41.3)	2.125 (53.9)	1.000 (25.4)	1.000 (25.4)	1.125 (28.6)	2.625 (66.7)	3.250 (82.6)	1.125 (28.6)	2.625 (66.7)	1 <sup>1</sup> / <sub>16</sub> -12	.375 (9.5)
3.00 (76)	10.25 (260)	1.015 (25.8)	1.938 (49.2)	2.125 (53.9)	1.125 (28.6)	1.125 (28.6)	1.125 (28.6)	2.625 (66.7)	3.750 (95.3)	1.125 (28.6)	2.625 (66.7)	1 <sup>1</sup> / <sub>4</sub> -12	.500 (12.7)
3.50 (89)	10.25 (260)	1.015 (25.8)	2.000 (50.8)	2.125 (53.9)	1.125 (28.6)	1.125 (28.6)	1.250 (31.8)	2.750 (69.8)	4.250 (107.9)	1.250 (31.8)	2.750 (69.8)	1 <sup>1</sup> / <sub>4</sub> -12	.562 (14.3)
4.00 (102)	10.62 (270)	1.015 (25.8)	2.000 (50.8)	2.125 (53.9)	1.125 (28.6)	1.125 (28.6)	1.250 (31.8)	2.875 (73.0)	5.000 (127)	1.250 (31.8)	2.750 (69.8)	1 <sup>1</sup> / <sub>4</sub> -12	.625 (15.9)

**SEE DH-ASAE** Cylinders on Page 4 for special closed center and clevis pins specifications on certain 8 & 16 inch stroke cylinders.

**Port Sizes:** 9/16-18 SAE are standard on 2" & 2 1/2" bores  
 3/4 - 16 SAE standard on 3" through 4" bores  
*NPTF threads are not available*



# HYDRAULIC CYLINDERS

TIE ROD CYLINDERS  
DH SERIES  
Specification Sheet

## STANDARD DH CYLINDER SIZES

Description	Rod Dia. *	Closed Center	**
208DH-ASAE	1.06	20.25	3000
210DH	1.06	20.25	3000
212DH	1.06	22.25	3000
214DH	1.06	24.25	3000
216DH	1.12	26.25	3000
218DH	1.12	28.25	3000
220DH	1.12	30.25	2387
224DH	1.12	34.25	1783
230DH	1.12	40.25	1225
2508DH-ASAE	1.25	20.25	3000
2510DH	1.25	20.25	3000
2512DH	1.25	22.25	3000
2514DH	1.25	24.25	3000
2516DH	1.25	26.25	3000
2518DH	1.25	28.25	2802
2520DH	1.25	30.25	2363
2524DH	1.25	34.25	1752
2530DH	1.25	40.25	1202
308DH-ASAE	1.25	20.25	3000
310DH	1.25	20.25	3000
312DH	1.25	22.25	3000
314DH	1.50	24.25	3000
316DH-ASAE	1.50	31.50	3000
318DH	1.50	28.25	3000
320DH	1.50	30.25	3000
324DH	1.50	34.25	2455
330DH	1.50	40.25	1691
336DH	1.50	46.25	1231
3508DH-ASAE	1.25	20.25	3000
3510DH	1.25	20.25	3000
3512DH	1.50	22.25	3000
3514DH	1.50	24.25	3000
3516DH-ASAE	1.50	31.50	3000
3518DH	1.50	28.25	3000
3520DH	1.75	30.25	3000
3524DH	1.75	34.25	3000
3530DH	1.75	40.25	2333
3536DH	1.75	46.25	1694
408DH-ASAE	1.25	20.25	3000
410DH	1.50	20.62	3000
412DH	1.50	22.62	3000
414DH	1.50	24.62	3000
416DH-ASAE	2.00	31.50	3000
418DH	2.00	28.62	3000
420DH	2.00	30.62	3000
424DH	2.00	34.62	3000
430DH	2.00	40.62	3000
436DH	2.00	46.62	2240

\* Piston rods are sized with a safety factor of 2. \*\* Max. PSI at base port due to column loading.



**ORDERING INFORMATION**

SERIES	BORE DIA. INCH X 100	STROKE INCH X 100	ROD DIA. INCH X 100	PORT SIZE (SAE ONLY)	END MOUNT ING	CLEVIS PIN	OTHER
DH	200	AS	106	C - 9/16-18 SAE	C	A. 1.00 STEEL	0 - NONE
	250	REQUIRED	112	D - 3/4-16 SAE	CLEVIS (STD.)	B. 1.00 HARD	X SPECIFY
	300		125			C. 1.25 HARD	
	350		150				
	400		175				
			200				

**ASAE STANDARD CYLINDERS**

The DH-ASAE cylinders are designed for use where 8" and 16" stroke ASAE cylinders are required to match specifications on certain types of equipment. Pin sizes and closed centers are standardized on these cylinders to match ASAE specifications. Therefore, no additional options are available.

MODEL NUMBER	BORE DIA. INCHES	STROKE INCHES	ROD DIA. INCHES	CLOSED CTR. DIM. INCHES	PORTING	CLEVIS PIN	WEIGHT LBS.
208DH-ASAE	2	8	1.06	20.25	9/16-18 SAE	1"	18
2508DH-ASAE	2 1/2	8	1.25	20.25	9/16-18 SAE	1"	20
308DH-ASAE	3	8	1.25	20.25	3/4-16 SAE	1"	24
3508DH-ASAE	3 1/2	8	1.25	20.25	3/4-16 SAE	1"	30
408DH-ASAE	4	8	1.25	20.25	3/4-16 SAE	1"	37
316DH-ASAE	3	16	1.50	31.50	3/4-16 SAE	1 1/4"	35
3516DH-ASAE	3 1/2	16	1.50	31.50	3/4-16 SAE	1 1/4"	51
416DH-ASAE	4	16	2.00	31.50	3/4-16 SAE	1 1/4"	65



CROSS MANUFACTURING, INC.

100 Factory Street

Lewis, KS 67552

Phone 620/324-5525; Fax 620/324-5737; e-mail: [info@crossmfg.com](mailto:info@crossmfg.com)



# HYDRAULIC CYLINDER SAFETY

## General Cautions:

- Always use a relief or bypass in your hydraulic system to prevent personal injury and/or breakage of equipment or components. Never operate a cylinder above rated pressures.
- Never use a cylinder as a transport device.
- Use correct fittings and proper hydraulic oil - Contact CROSS if you have questions.

## Binding

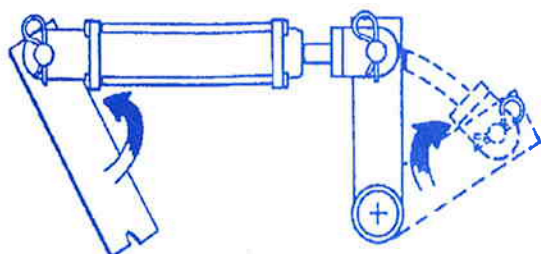

Check clevis clearances before, during and after extending the cylinder and before using the cylinder under pressure to avoid possible injury, or bent or broken rods or clevises caused by binding.

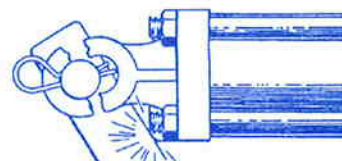

## Too much pressure causes...

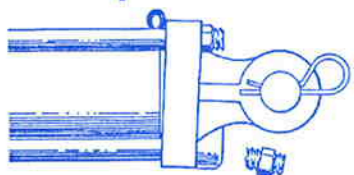

Extruded static seals and/or broken tie rods. Check pressure rating of cylinder against pump pressure of the tractor.

## Rough or scored rod

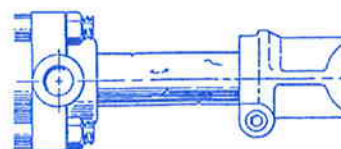

Protect the rod at all times and make sure that nothing hits or rubs it when it is extended. Rough places on the rod damage the seals and reduce their normal life resulting in the necessity for frequent replacement.

## Dirty Oil

Oil must be filtered to a minimum of 25 microns. Filters should be changed regularly - spin-on types after 50 hours of initial use and then after every two hundred fifty hours of use. Use of a condition indicator is recommended. Consult your tractor or implement owner's manual for filtration and changing recommendations for internal systems

## Pinhole Leaks

If you observe a pinhole leak, discontinue use of the component. If oil has penetrated your skin or contacted your eye, seek medical attention immediately!



[www.crossmfg.com](http://www.crossmfg.com)

**MANUFACTURING, INC.**

LEWIS, KANSAS

PHONE 620/324-5525

FAX 620/324-5737

CROSS MANUFACTURING INC. RESERVES THE RIGHT TO DISCONTINUE PRODUCTS AND / OR CHANGE DESIGN, SPECIFICATIONS OR PRICES AT ANY TIME WITHOUT INCURRING ANY OBLIGATION.

CYL30077C 5/02